

CARACTERISTICAS / FEATURES

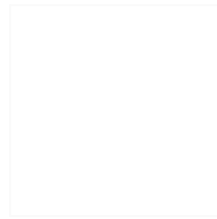

Material hormigón Petra 1
Acabado decapado e hidrofugado
Dimensiones Ø 220, h. 74 cm
Color ver carta de colores
Fijación apoyado por su propio peso
Peso 1200 kg, 1018 L
Palet 230 x 230 cm

Material precast concrete Petra 1
Finish scaled and waterproofed
Dimensions Ø 220, h. 74 cm
Colour see colour catalogue
Fixing resting on the ground
Weight 1,200 kg, 1,018 L
Pallet 230 x 230 cm

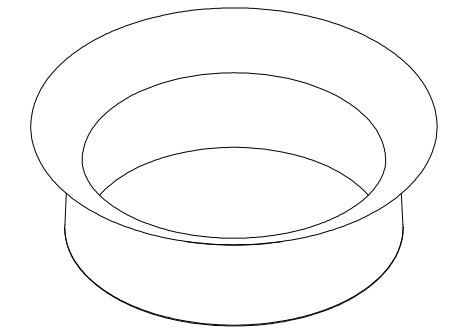

diseñador / design: magourban

HAT J-220

GEOMETRIA / GEOMETRY

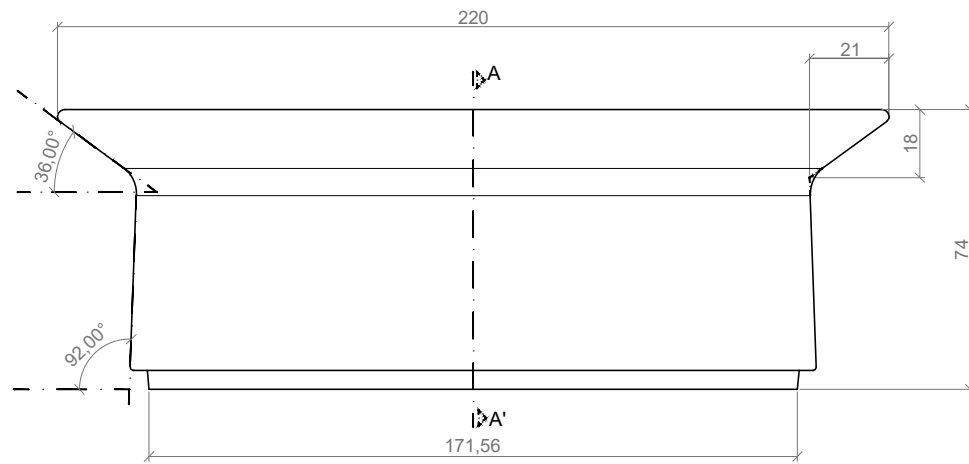

ALZADO / FRONT VIEW

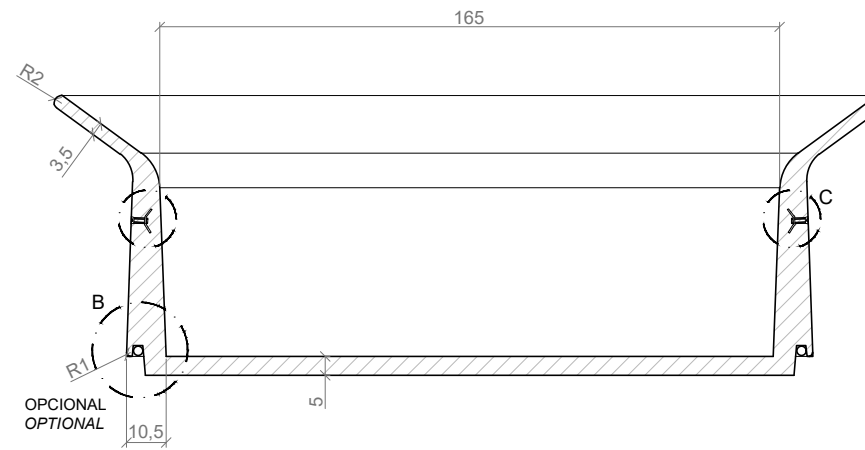

SECCION A-A' / SECTION A-A'

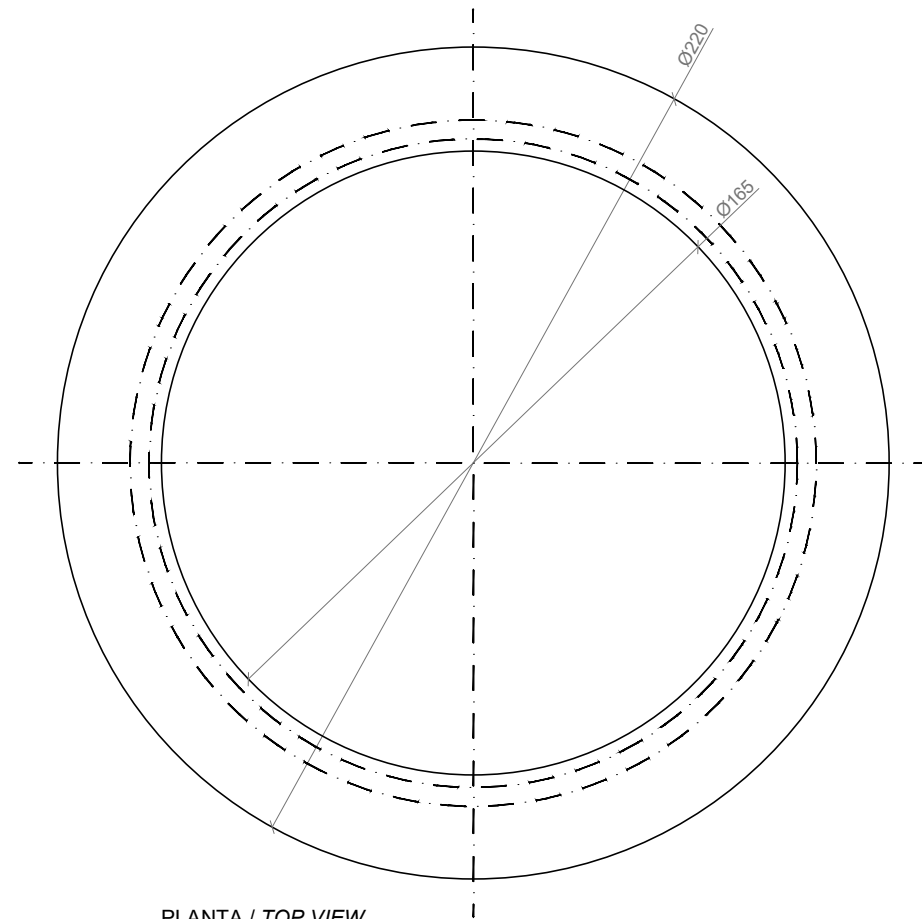

PLANTA / TOP VIEW

ESC. 1:20

MANIPULACION E INSTALACION
HANDLING AND INSTALLATION

Elevación / Hoisting
P= 1.200 kg

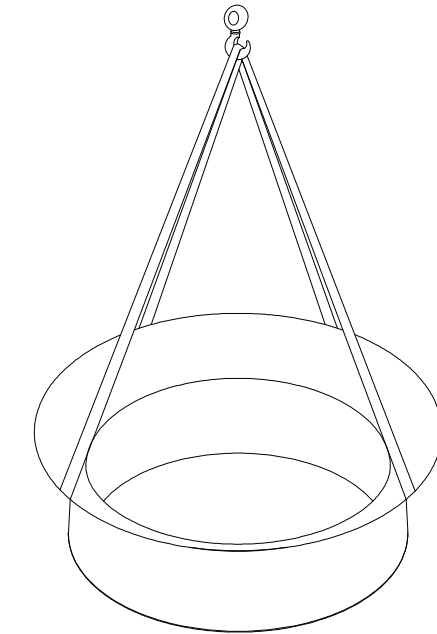

ESPECIFICACIONES / SPECIFICATIONS

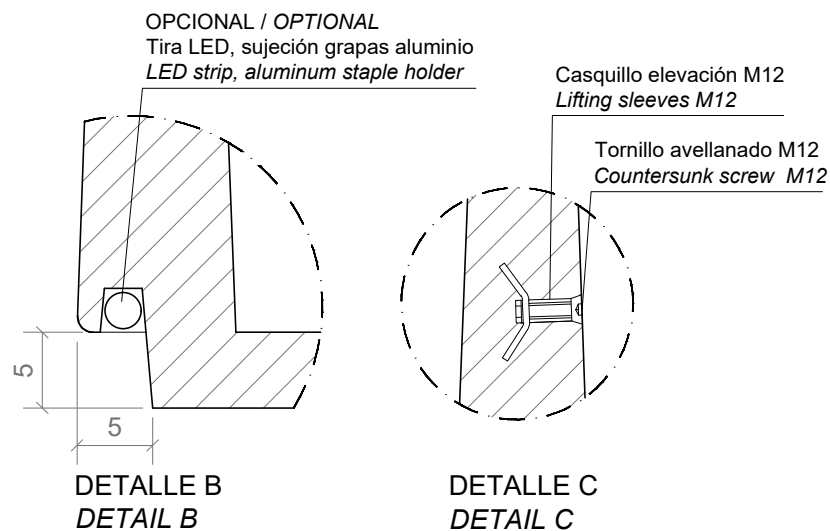

ESC. 1:5