

CARACTERISTICAS / FEATURES

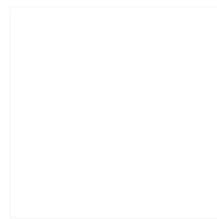

Material hormigón Petra 1
Acabado decapado e hidrofugado
Dimensiones Ø 115, h. 74 cm
Color ver carta de colores
Fijación apoyado por su propio peso
Peso 472 kg, 532 L
Palet 125 x 125 cm

Material precast concrete Petra 1
Finish scaled and waterproofed
Dimensions Ø 115, h. 74 cm
Colour see colour catalogue
Fixing resting on the ground
Weight 472 kg, 532 L
Pallet 125 x 125 cm

diseñador / design: magourban

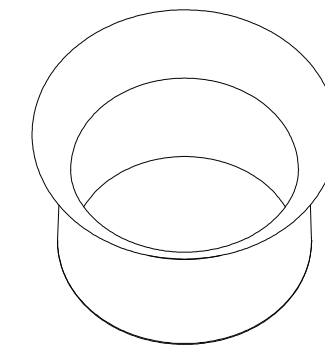

HAT J-115

GEOMETRIA / GEOMETRY

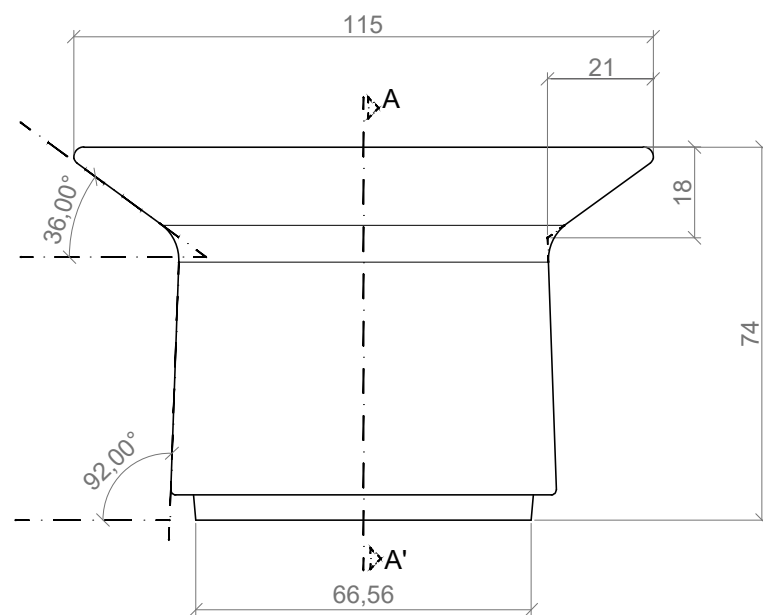

ALZADO / FRONT VIEW

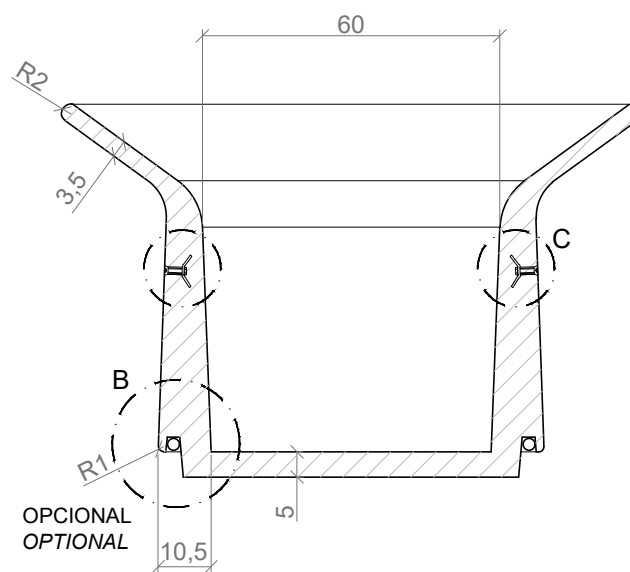

SECCION A-A' / SECTION A-A'

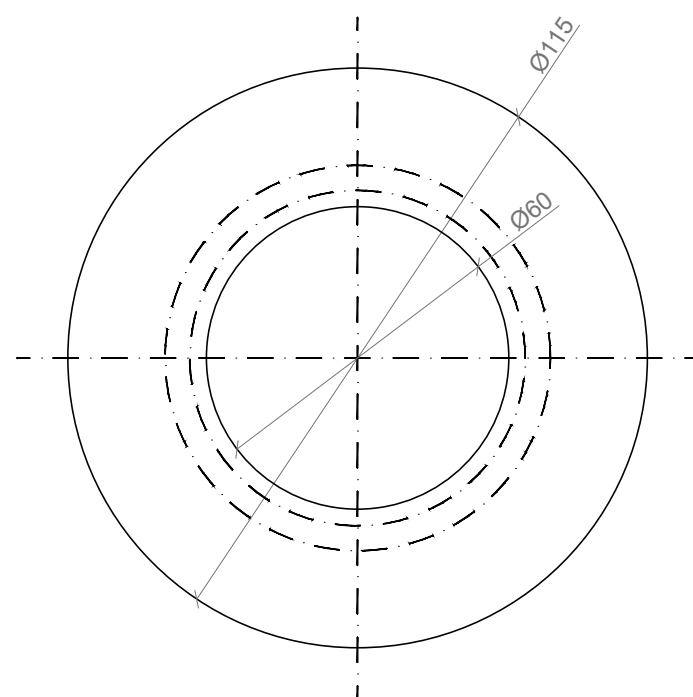

PLANTA / TOP VIEW

ESC. 1:15

ESPECIFICACIONES / SPECIFICATIONS

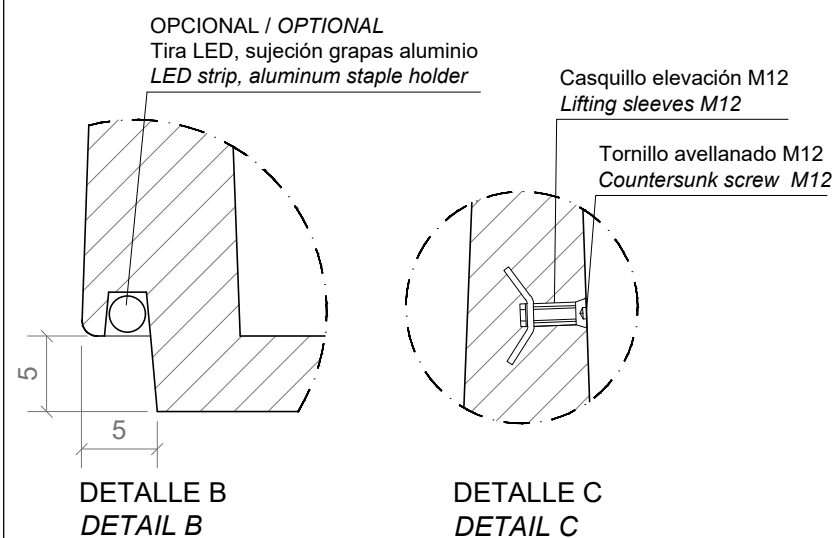

ESC. 1:5

MANIPULACION E INSTALACION / HANDLING AND INSTALLATION

