

CARACTERISTICAS / FEATURES

Material SMC
Acabado liso
Dimensiones l. 65, a. 53, h. 72 cm
Color ver carta de colores
Fijación con varillas metálicas y resina epoxi
Peso 80 kg
Palet 120 x 80 x 90h cm (2 unidades)
Peso palet 180 kg

Material SMC
Finish smooth
Dimensions l.65, w.53, h. 72 cm
Colour see colour catalogue
Fixing with metal rods and epoxy resin
Weight 80 kg
Pallet 120 x 80 x 90h cm (2 units)
Weight pallet 180 kg

diseñador / design: Ton Riera

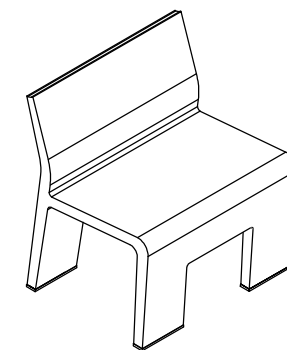

BLINK C

GEOMETRIA / GEOMETRY

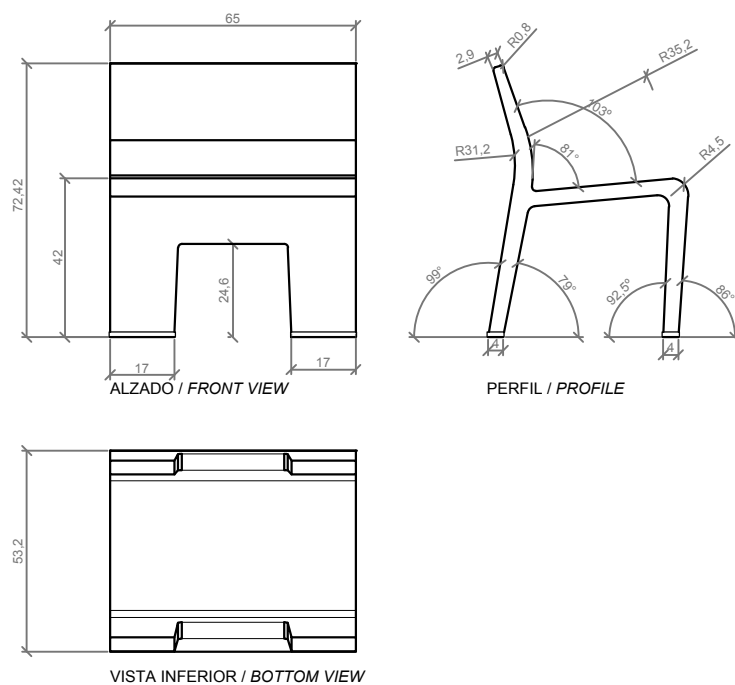

ESCALA / SCALE: 1/20

MANIPULACION E INSTALACION / HANDLING AND INSTALLATION

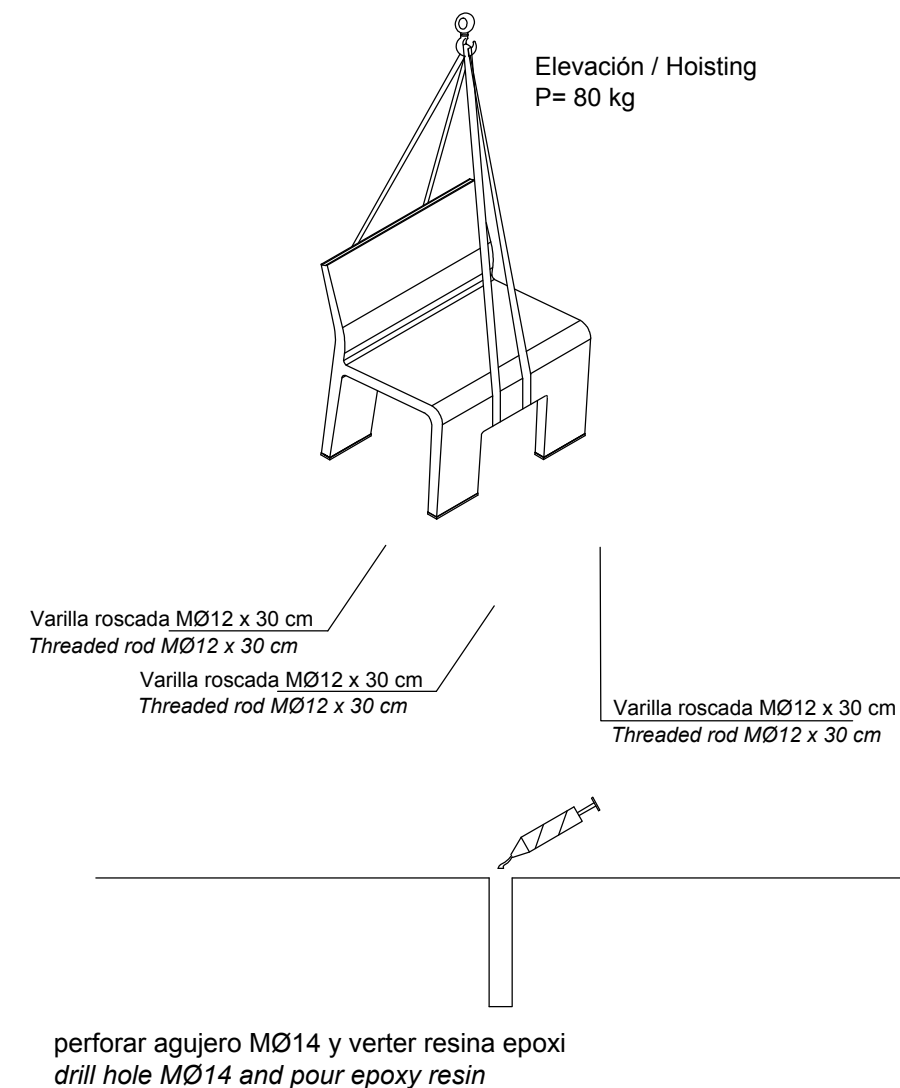

ESPECIFICACIONES / SPECIFICATIONS

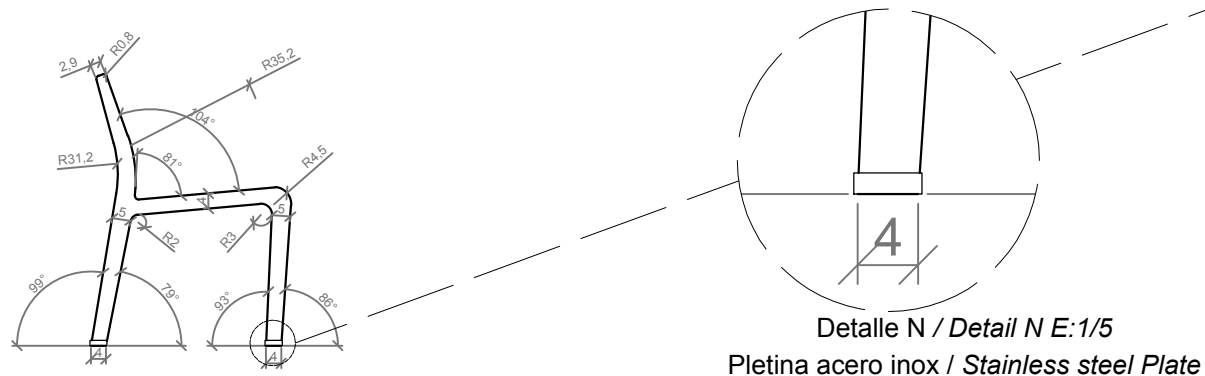

ESCALA / SCALE: 1/20