

**CARACTERISTICAS / FEATURES**

**Material** hormigón Petra 1  
**Acabado** decapado e hidrofugado  
**Dimensiones** l. 100, a. 50, h. 45 cm  
**Color** ver carta de colores  
**Fijación** apoyado por su propio peso  
**Peso** 525 kg  
**Palet** 110 x 55 cm

**Material** precast concrete Petra 1  
**Finish** scaled and waterproofed  
**Dimensions** l.100, w.50, h. 45 cm  
**Colour** see colour catalogue  
**Fixing** resting on the ground  
**Weight** 525 kg  
**Pallet** 110 x 55 cm

diseñador / design: magourban

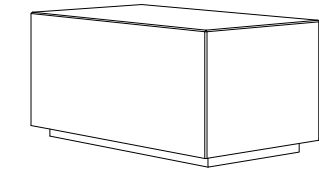

**DYNAMIC I-100**

**GEOMETRIA / GEOMETRY**

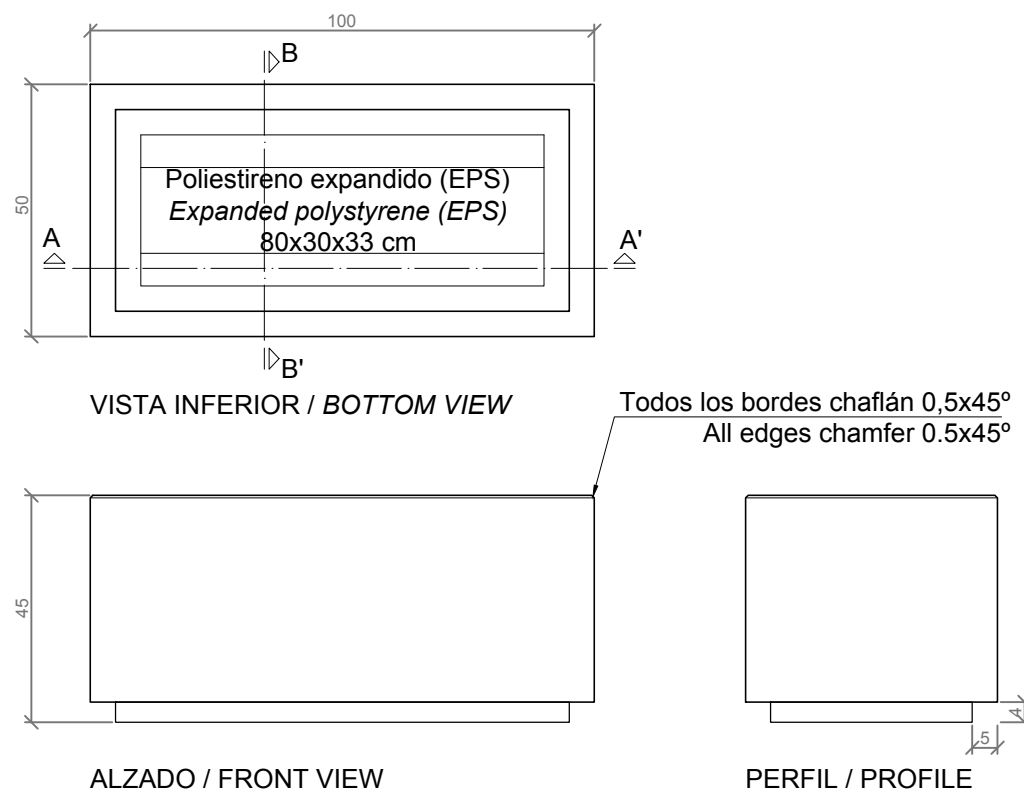

ESC: 1/15

**MANIPULACION E INSTALACION / HANDLING AND INSTALLATION**

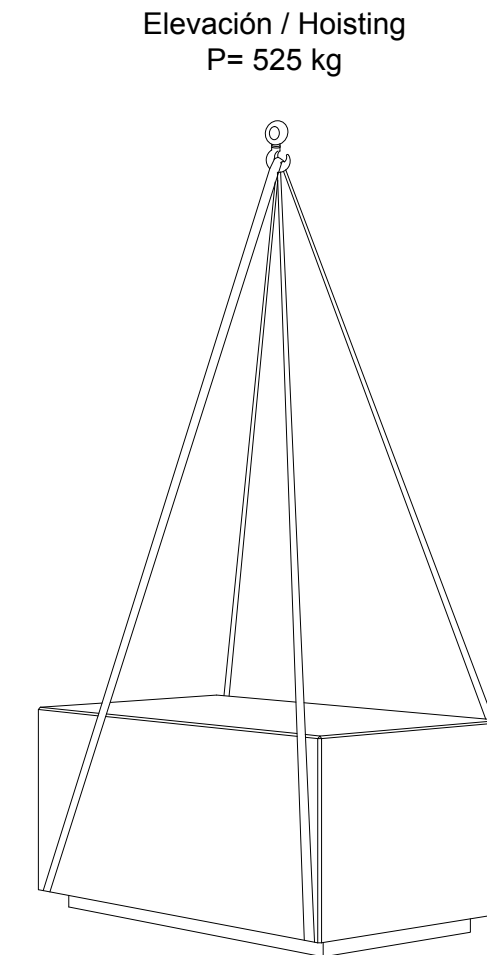

**ESPECIFICACIONES / SPECIFICATIONS**

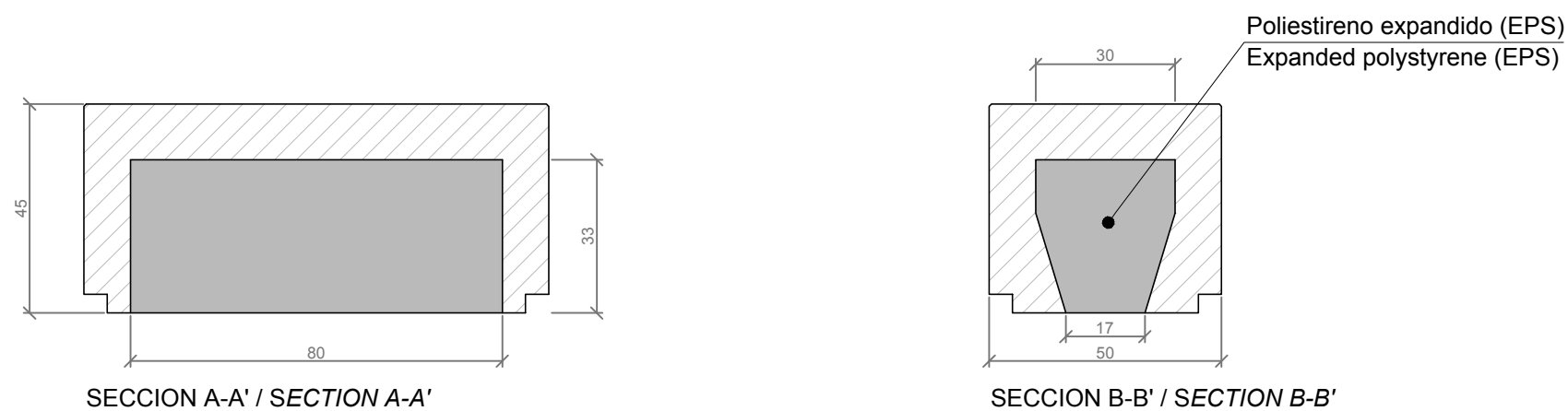

ESC: 1/15