

CARACTERISTICAS / FEATURES

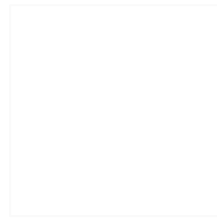

Material hormigón Petra 1
Acabado decapado e hidrofugado
Dimensiones l. 210, a. 55, h. 45 cm
Color ver carta de colores
Fijación apoyado por su propio peso o mediante resina epoxi
Peso 750 kg
Palet 220 x 60 cm

Material precast concrete Petra 1
Finish scaled and waterproofed
Dimensions l. 210, w. 55, h. 45 cm
Colour see colour catalogue
Fixing resting on the ground or with epoxy resin
Weight 750 kg
Pallet 220 x 60 cm

diseñador / design: magourban



GEOMETRIA / GEOMETRY

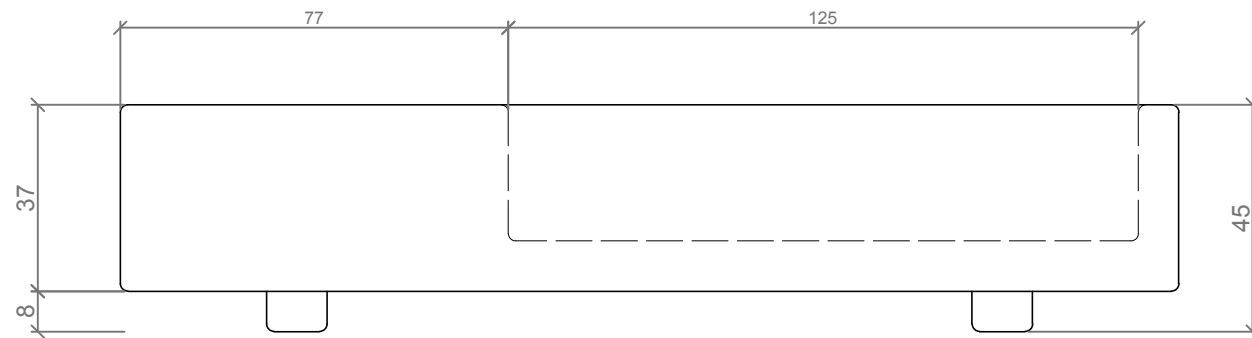

ALZADO / FRONT VIEW

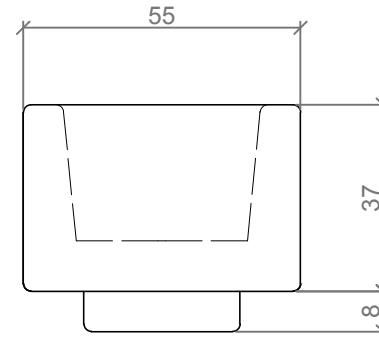

PERFIL / PROFILE

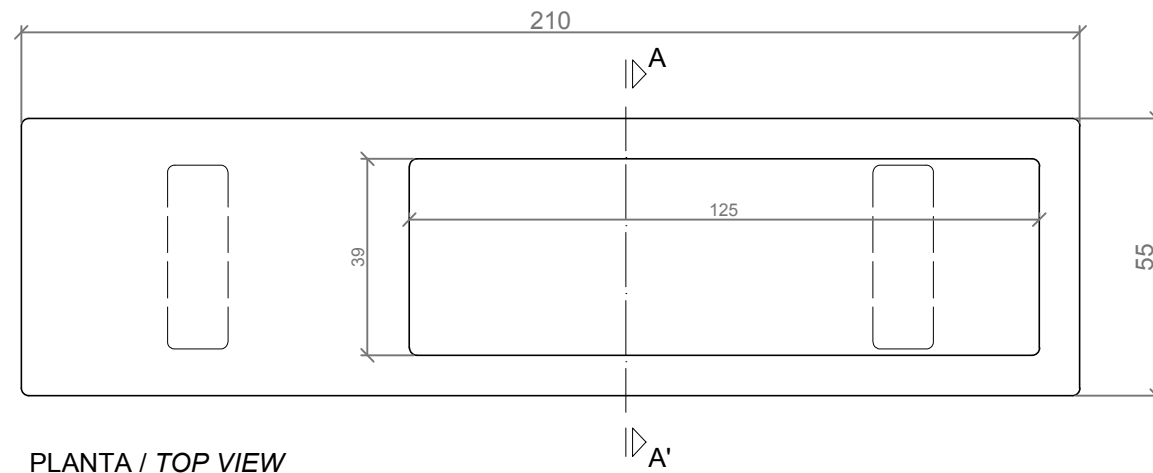

PLANTA / TOP VIEW

ESC. 1:15

MANIPULACION E INSTALACION / HANDLING AND INSTALLATION

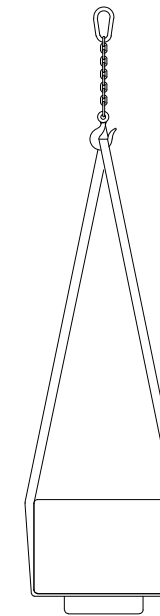

Elevación / Hoisting
P= 750 kg

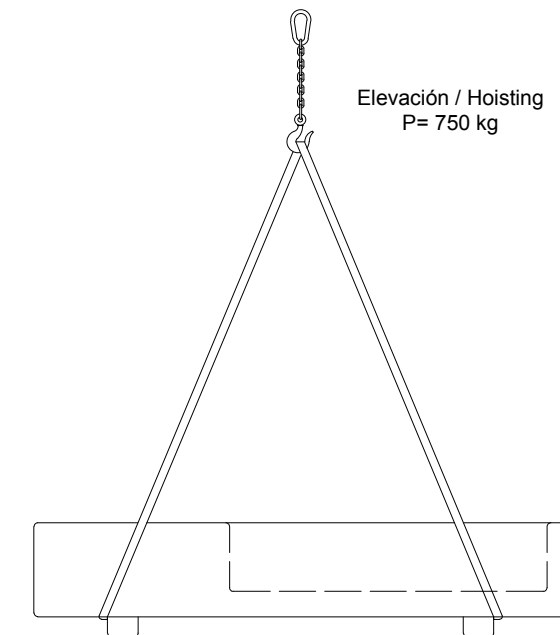

ESPECIFICACIONES / SPECIFICATIONS

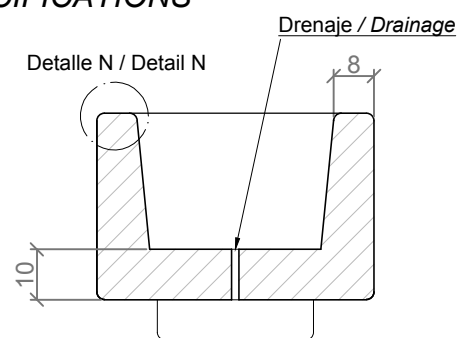

SECCION A-A' / SECTION A-A'

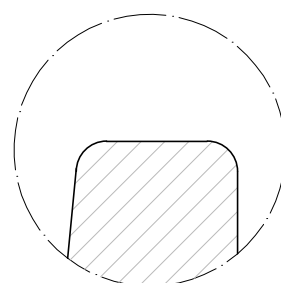

DETALL N / DETAIL N