

CARACTERISTICAS / FEATURES

Material hormigón Petra 1
Acabado decapado e hidrofugado
Dimensiones l. 50, a. 50, h. 45 cm
Color ver carta de colores
Fijación apoyado por su propio peso
Peso 285 kg
Palet 110 x 110 cm (4 unidades)

Material precast concrete Petra 1
Finish scaled and waterproofed
Dimensions l.50, w.50, h. 45 cm
Colour see colour catalogue
Fixing resting on the ground
Weight 285 kg
Pallet 110 x 110 cm (4 units)

diseñador / design: magourban

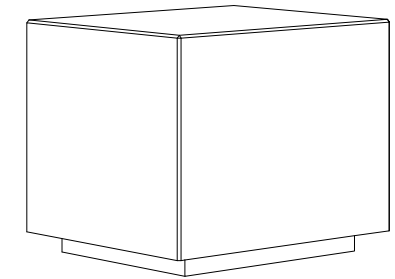

DYNAMIC Q-50

GEOMETRIA / GEOMETRY

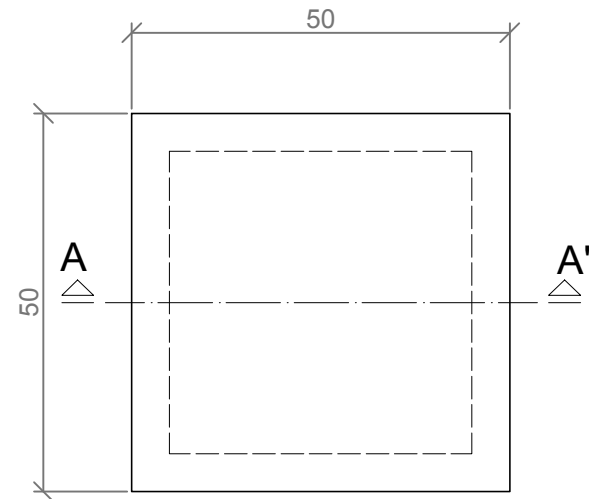

PLANTA / TOP VIEW

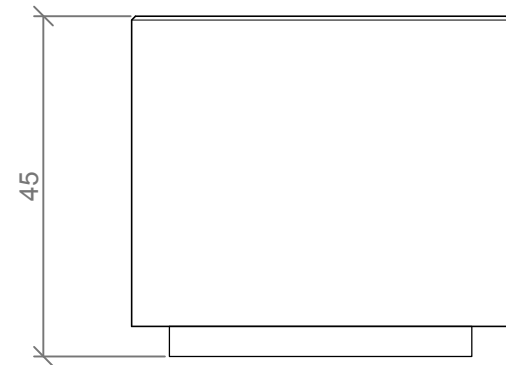

ALZADO / FRONT VIEW

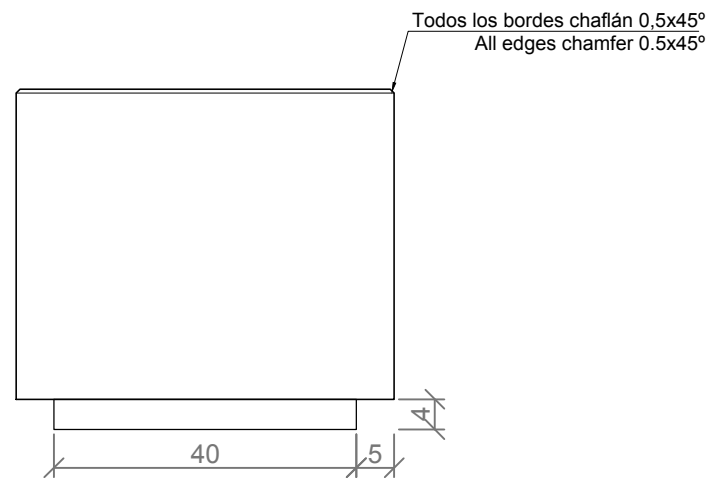

PERFIL / PROFILE

ESC: 1/10

MANIPULACION E INSTALACION / HANDLING AND INSTALLATION

1 Enroscar la varilla / Thread the rod

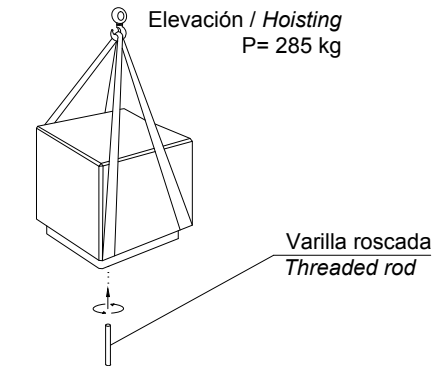

2 Perforar agujero y verter resina epoxi dentro / Drill hole and pour epoxy resin into the hole

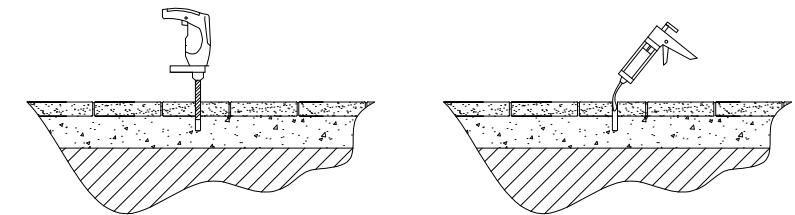

3 Insertar varilla roscada en agujero
 Insert metal threaded rod in hole

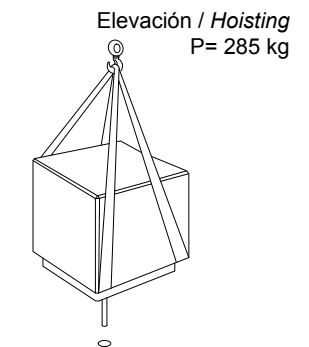

ESPECIFICACIONES / SPECIFICATIONS

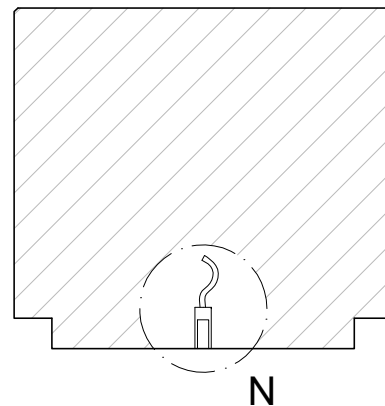

SECCION A-A' / SECTION A-A'

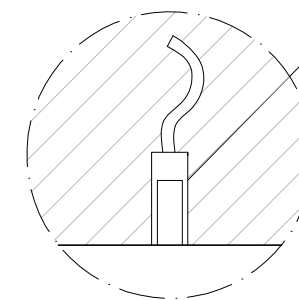

DETALLE N / DETAIL N

Casquillo M12 - Tubo acero zincado alta precisión
 Tube M12 - Galvanized steel pipe high precision

ESC: 1/10