

CARACTERÍSTICAS / FEATURES

Material hormigón Petra 1
Acabado decapado e hidrofugado
Dimensiones l. 200, a. 80, h. 110 cm
Color ver carta de colores
Fijación apoyado por su propio peso y con resina epoxi
Peso 1050 kg
Palet 210 x 90 x 130 h cm
Peso palet 1130 kg

Material concrete Petra 1
Finish scaled and waterproofed
Dimensions l. 200, w. 80, h. 110 cm
Colour see colour catalogue
Fixing by its own weight and with epoxy resin
Weight 1,050 kg
Pallet 210 x 90 x 130 cm
Weight pallet 1,130 kg

diseñador / design: magourban

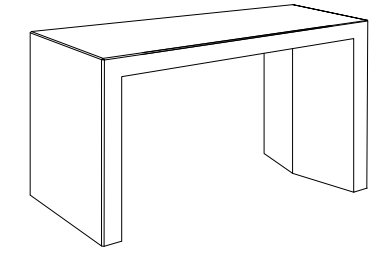

TARGA T 110

GEOMETRIA / GEOMETRY

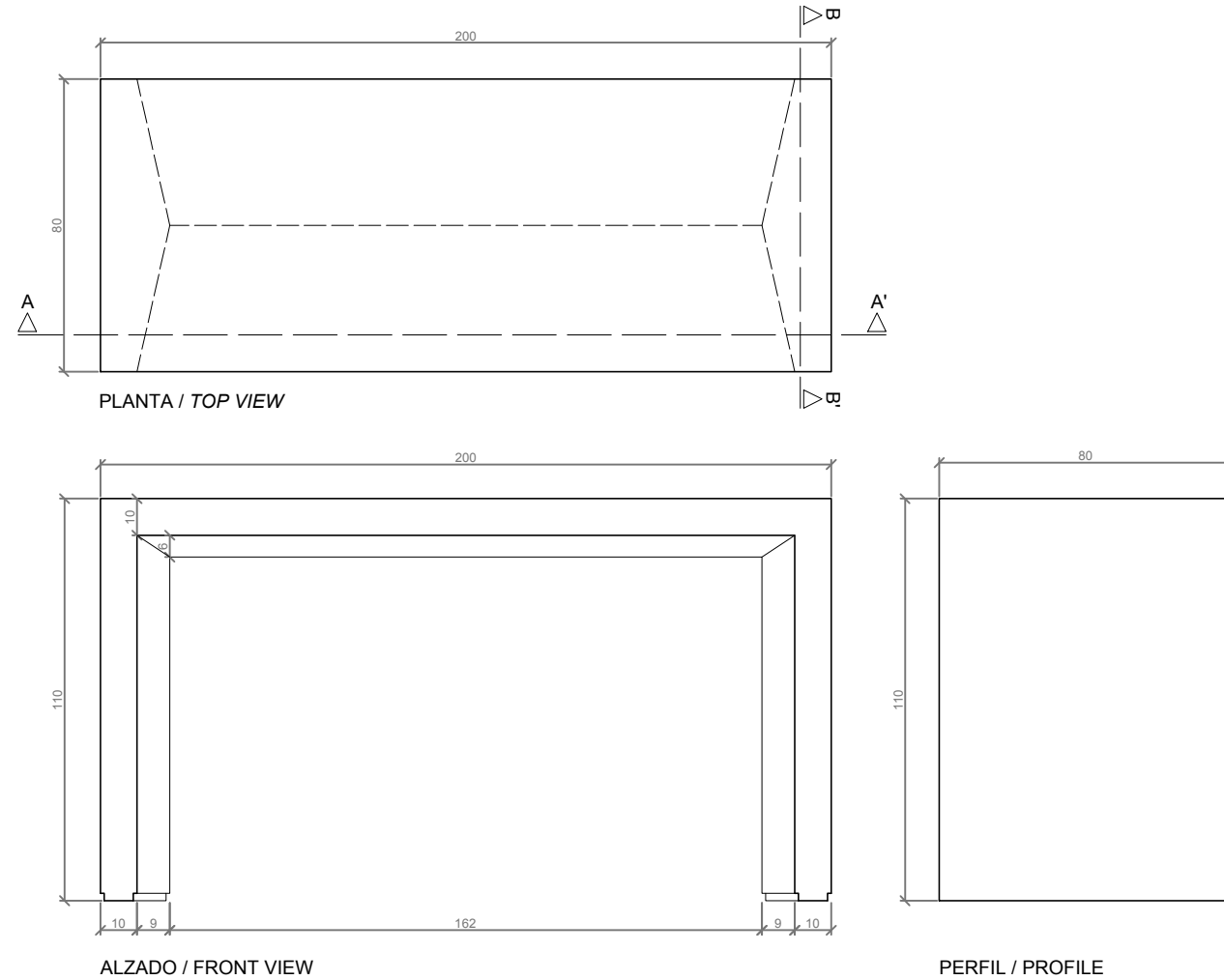

ESCALA / SCALE 1/20

MANIPULACIÓN E INSTALACIÓN HANDLING AND INSTALLATION

- 1 Elevar y enroscar la varilla
Lift and thread the rod

MUY IMPORTANTE / VERY IMPORTANT
 proteger las esquinas con espuma del embalaje
 protect the corners with packing foam

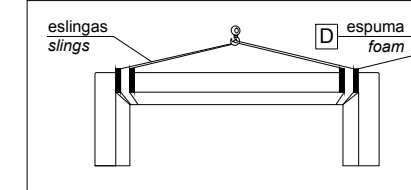

elevación / hoisting
 P= 930 kg

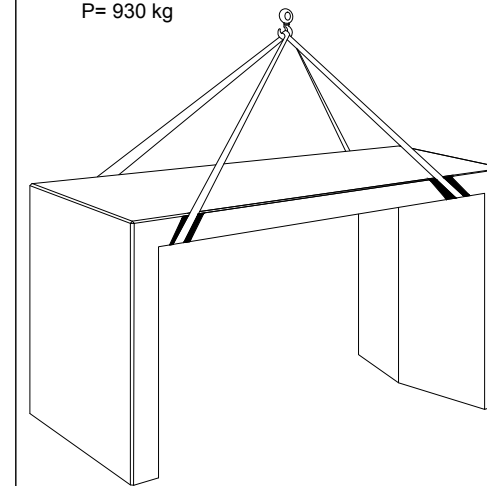

- 2 Verter resina epoxi / Pour epoxy resin

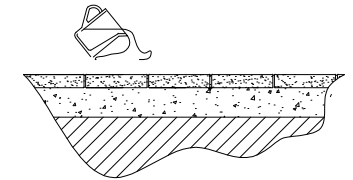

- 3 Colocar el banco / Place the bench

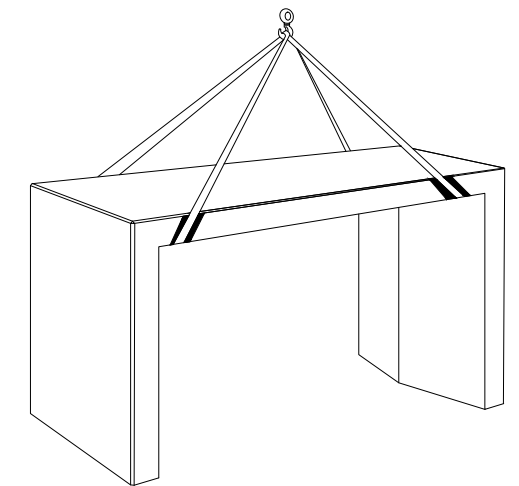

ESPECIFICACIONES / SPECIFICATIONS

