

CARACTERISTICAS / FEATURES



Material hormigón Petra 1
Acabado decapado e hidrofugado
Dimensiones l. 90, a. 90, h. 45 cm
Color ver carta de colores
Fijación apoyado por su propio peso o mediante resina epoxi
Peso 600 kg
Palet 100 x 100 cm

Material precast concrete Petra 1
Finish scaled and waterproofed
Dimensions l. 90, w. 90, h. 45 cm
Colour see colour catalogue
Fixing resting on the ground or with epoxy resin
Weight 600 kg
Pallet 100 x 100 cm

diseñador / design: Roger Albero

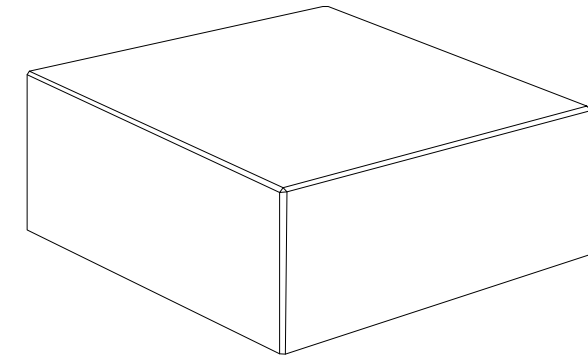

TETRIS Q-90

GEOMETRIA / GEOMETRY

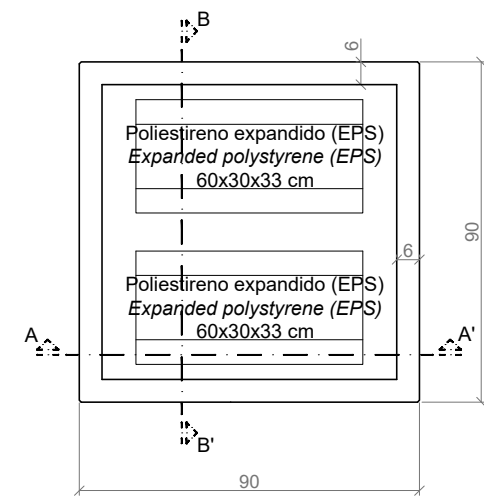

VISTA INFERIOR / BOTTOM VIEW

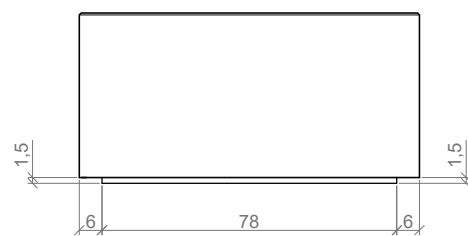

ALZADO / FRONT VIEW

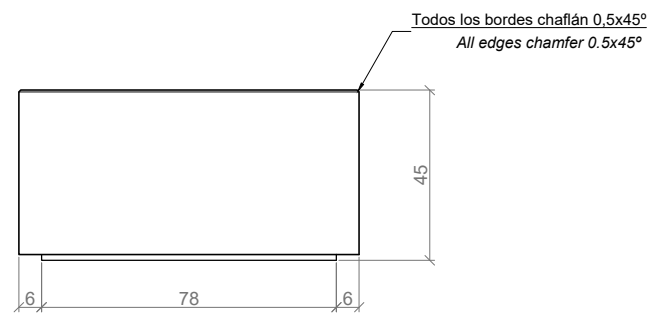

PERFIL / PROFILE

ESCALA / SCALE: 1/20

MANIPULACION E INSTALACION / HANDLING AND INSTALLATION

Elevar el banco mediante eslingas e instalar
 Lift the bench with slings and install

Elevación / Hoisting
 P= 600 kg

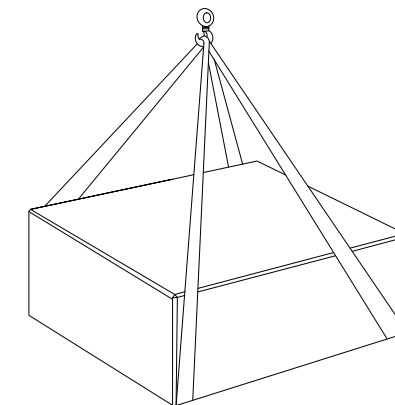

ESPECIFICACIONES / SPECIFICATIONS



SECCION A-A' / SECTION A-A'

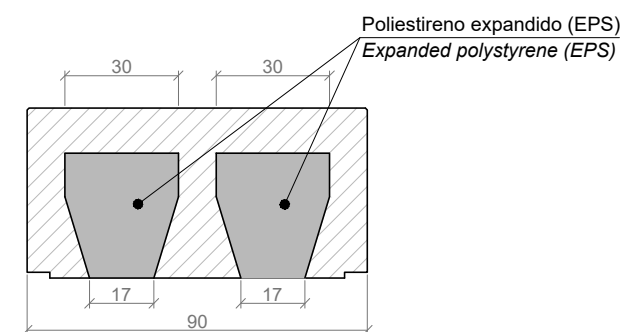

SECCION B-B' / SECTION B-B'

ESCALA / SCALE: 1/20