

CARACTERISTICAS / FEATURES

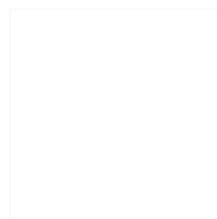

Material hormigón Petra 1
Acabado decapado e hidrofugado
Dimensiones l. 165, a. 153, h. 67 cm
Color ver carta de colores
Fijación apoyado por su propio peso o mediante resina epoxi
Peso 1160 kg
Palet 170 x 160 cm

Material precast concrete Petra 1
Finish scaled and waterproofed
Dimensions l. 165, w. 153, h. 67 cm
Colour see colour catalogue
Fixing resting on the ground or with epoxy resin
Weight 1160 kg
Pallet 170 x 160 cm

diseñador / design: magourban

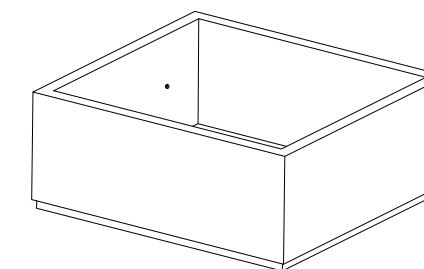

ESPACE

GEOMETRIA / GEOMETRY

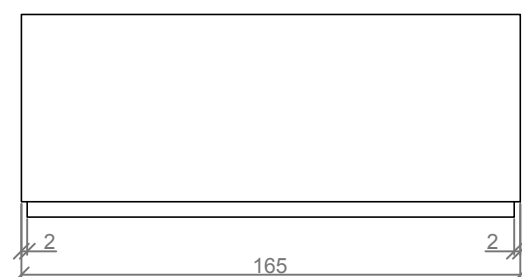

ALZADO / FRONT VIEW

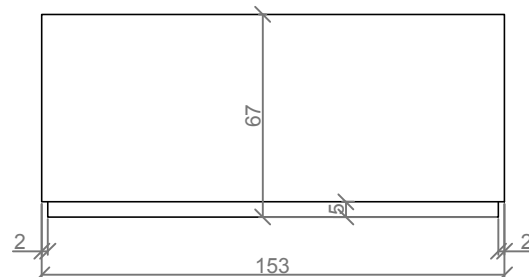

PERFIL / PROFILE VIEW

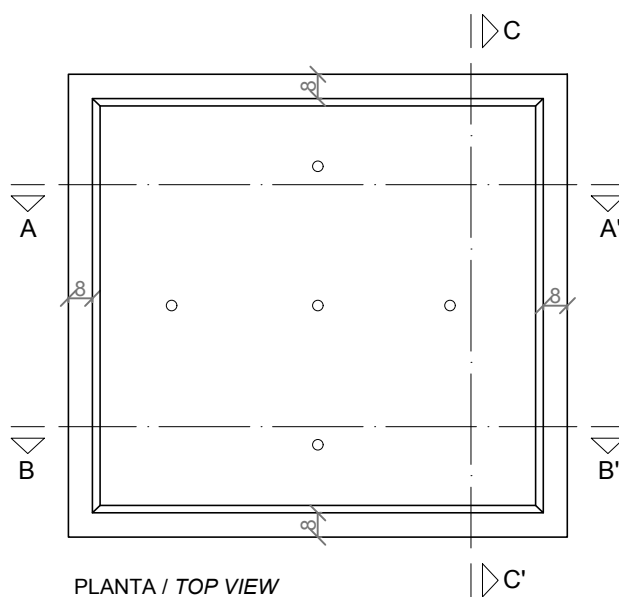

PLANTA / TOP VIEW

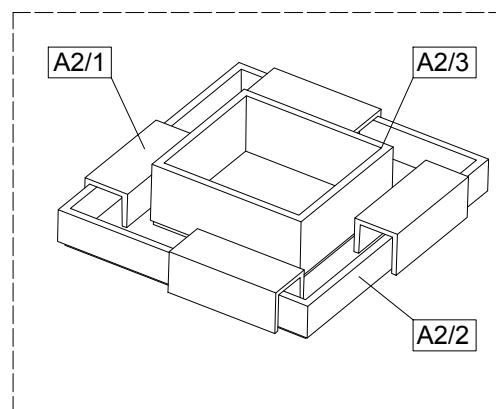

ESC. 1:25

MANIPULACION E INSTALACION / HANDLING AND INSTALLATION

- 1 Extraer tapa y enroscar cáncamo
Remove cap and screw eyebolt

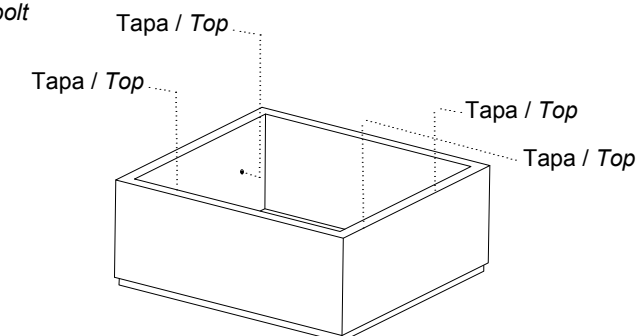

- 2 Elevar e instalar

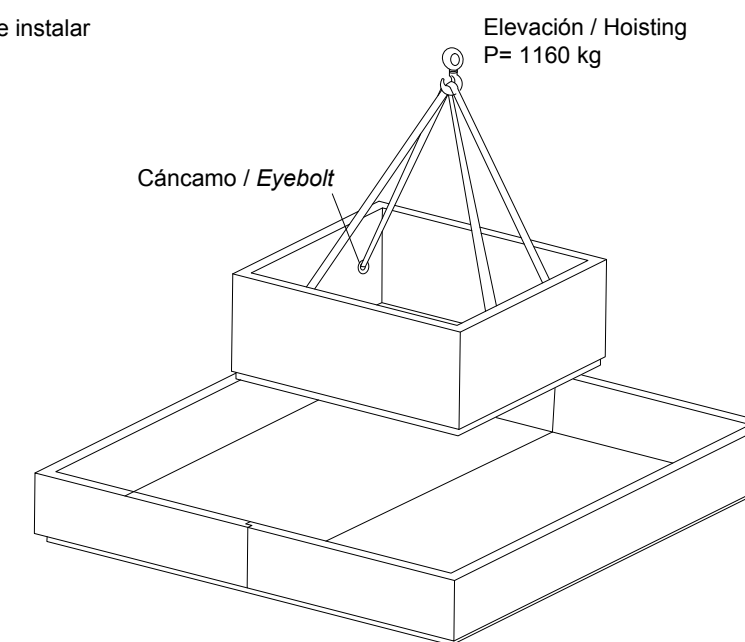

ESPECIFICACIONES / SPECIFICATIONS

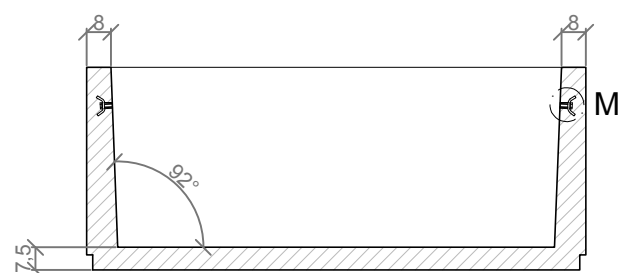

SECCION A-A' / SECTION A-A'

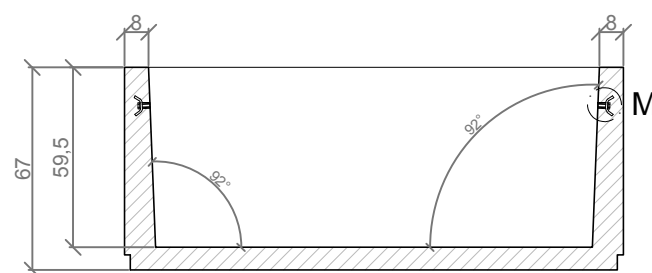

SECCION B-B' / SECTION B-B'

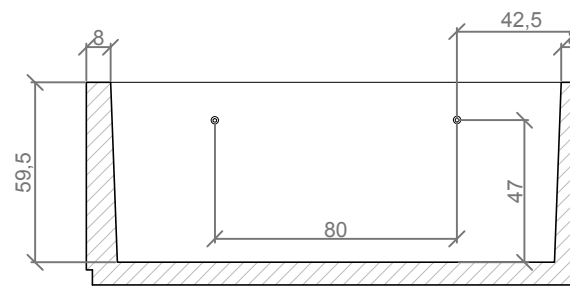

SECCION C-C' / SECTION C-C'

Tapa - Tornillo avellanado M16
Top - Countersunk screw M16

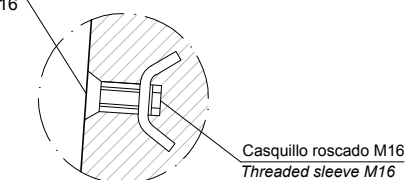

DETALLE M / DETAIL M

ESC. 1:25