

CARACTERISTICAS / FEATURES

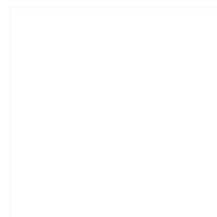

Material hormigón Petra 1
Acabado decapado e hidrofugado
Dimensiones l. 300, a. 120, h. 60 cm
Color ver carta de colores
Fijación por su propio peso o mediante resina epoxi
Peso 1170 kg
Palet 310 x 130 cm

Material precast concrete Petra 1
Finish scaled and waterproofed
Dimensions l. 300, w. 120, h. 60 cm
Colour see colour catalogue
Fixing resting on the ground or with epoxy resin
Weight 1170 kg
Pallet 310 x 130 cm

diseñador / design: magourban

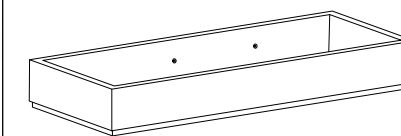

ESPACE R

GEOMETRIA / GEOMETRY

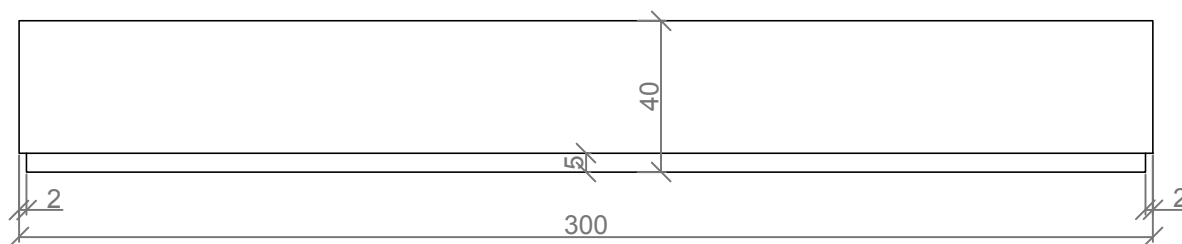

ALZADO / FRONT VIEW

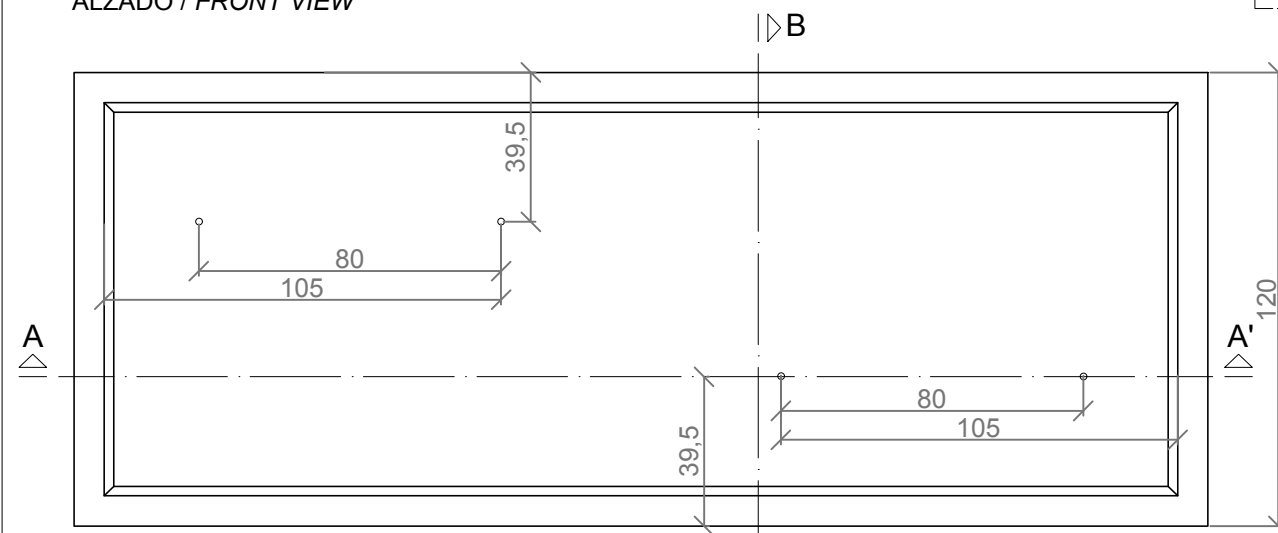
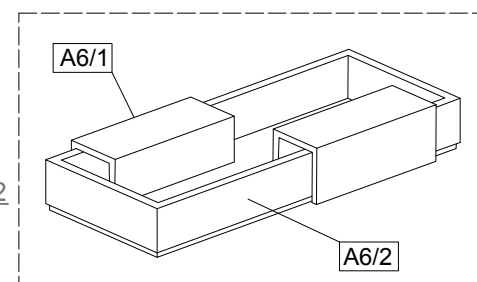

PLANTA / TOP VIEW

ESC. 1:20

MANIPULACION E INSTALACION / HANDLING AND INSTALLATION

- 1 Extraer tapa y enroscar cáncamo
Remove cap and screw eyebolt
- 2 Elevar e instalar
Lift and install

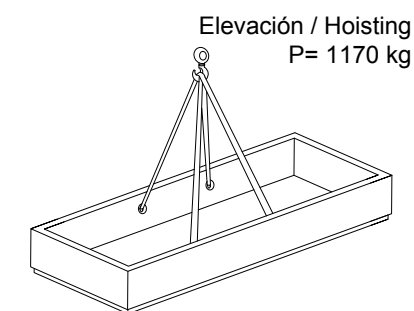
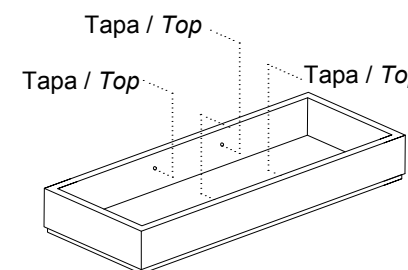

- 3 Verter resina epoxi e insertar la varilla en el agujero
Pour resin epoxy and insert the rod into the hole

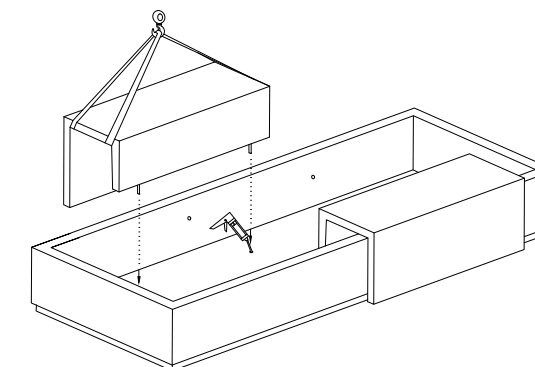

ESPECIFICACIONES / SPECIFICATIONS

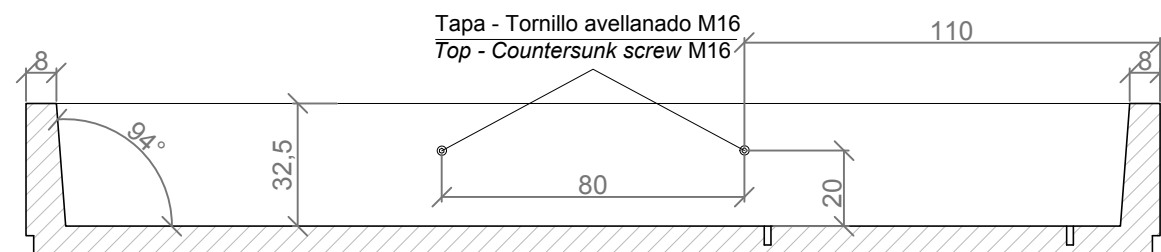

SECCION A-A' / SECTION A-A'

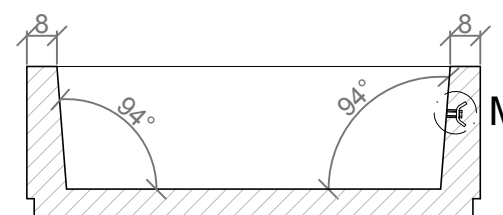

SECCION B-B' / SECTION B-B'

Tapa - Tornillo avellanado M16
Top - Countersunk screw M16

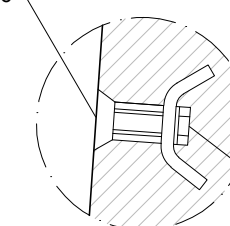

Casquillo M16 - Acero zincado alta precisión
Threaded sleeve M16 - Galvanized steel of high precision

DETALLE M / DETAIL M

ESC. 1:20