

CARACTERISTICAS / FEATURES

Material hormigón Petra 1
Acabado decapado e hidrofugado
Dimensiones Ø 71, h. 48 cm
Color ver carta de colores
Fijación apoyado por su propio peso o con resina epoxi
Peso 170 kg / 88 L
Palet 100 x 100 cm

Material precast concrete Petra 1
Finish scaled and waterproofed
Dimensions Ø 71, h. 48 cm
Colour see colour catalogue
Fixing resting on the ground or with epoxy resin
Weight 170 kg / 88 L
Pallet 100 x 100 cm

diseñador / design: kutarq studio + YHY design

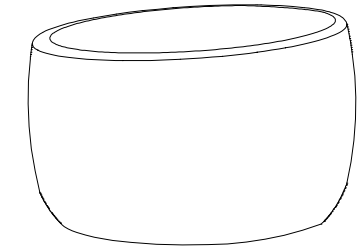

RUSSES J 71

GEOMETRIA / GEOMETRY

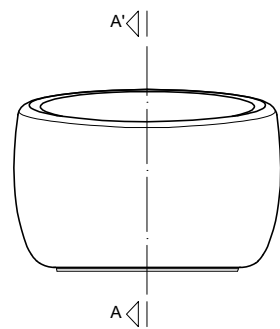

ALZADO / FRONT VIEW

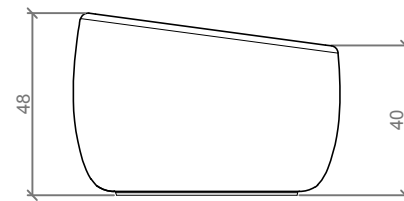

PERFIL / RIGHT SIDE

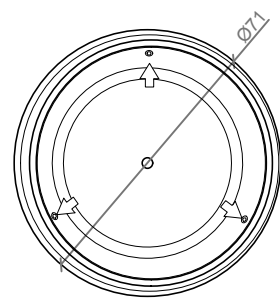

PLANTA / TOP VIEW

Ubicación del casquillo roscado
 Location of steel socket threaded

ESCALA / SCALE : 1/ 20

ESPECIFICACIONES / SPECIFICATIONS

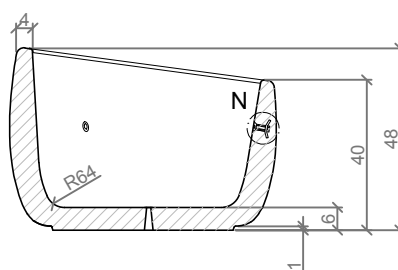

SECCION A-A' / SECTION A-A'

Casquillo M16 - Tubo acero zincado alta precisión
 Galvanized steel threaded sleeve M16 high precision

Tornillo avellanado M16
 Countersunk screw M16

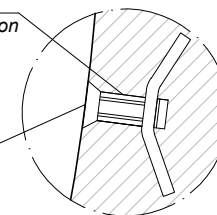

DETALLE N / DETAIL N

MANIPULACION E INSTALACION / HANDLING AND INSTALLATION

1 Extraer tapa / Extract stopper

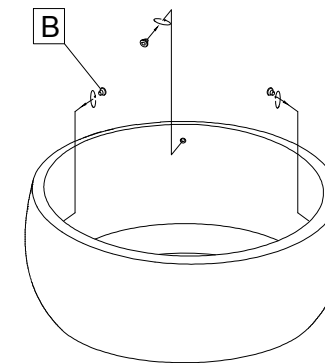

2 Enroscar cáncamo / Thread the eyebolt

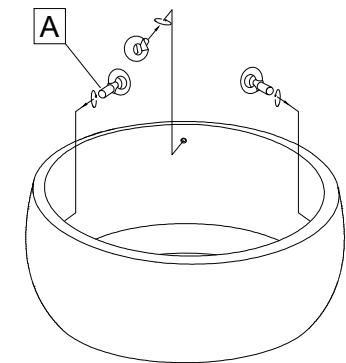

3 Verter resina epoxi / Pour resin epoxy

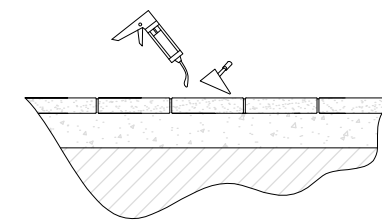

4 Elevar e instalar / Lift and install

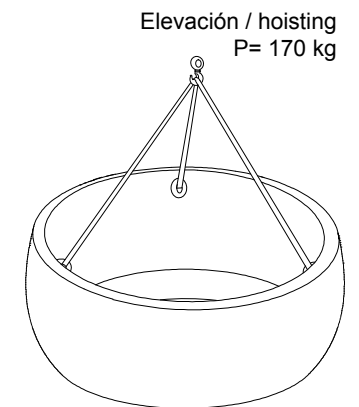

SISTEMA DE ELEVACION / LIFTING SYSTEM

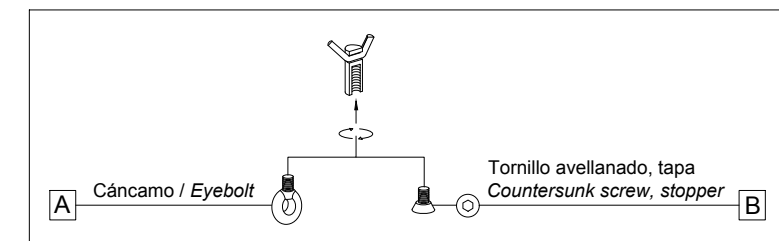

Tàrrega, Lleida - Tel. +34 973 15 87 03 - www.magourban.com - info@magourban.com

magourban

