

CARACTERISTICAS / FEATURES

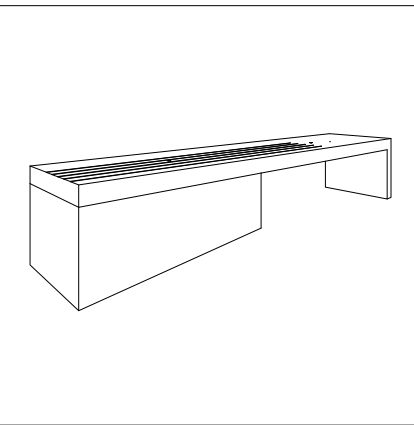

Material	hormigón Petra 1	Material	precast concrete Petra 1
Acabado	decapado e hidrofugado	Finish	scaled and waterproofed
Dimensiones	l. 320, a. 60, h. 45 cm	Dimensions	l. 320, w. 60, h. 45 cm
Color	ver carta de colores	Colour	see colour catalogue
Fijación	apoyado por su propio peso o mediante resina epoxi	Fixing	resting on the ground or with epoxy resin
Peso	970 kg	Weight	970 kg
Palet	330 x 70- cm	Pallet	330 x 70 cm

diseñador / design: Ventura Valcarce



MDT non plus

GEOMETRIA / GEOMETRY

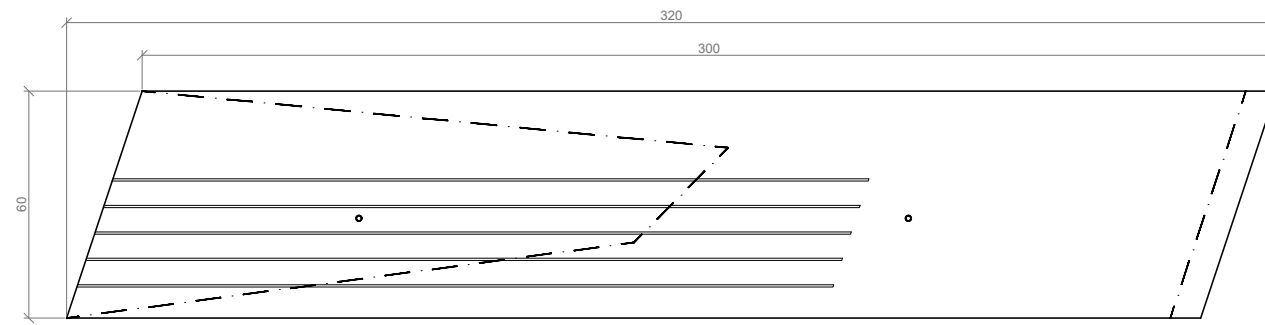

PLANTA / TOP VIEW

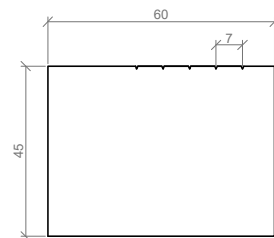

PERFIL / PROFILE

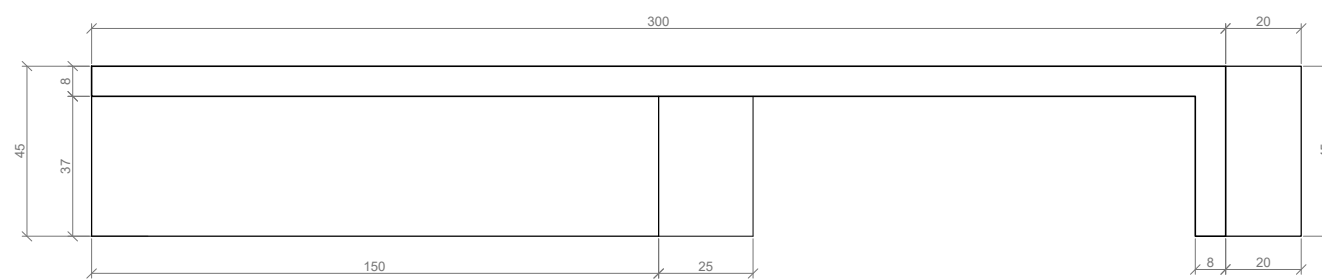

ALZADO / FRONT VIEW

ESC. 1:20

MANIPULACION E INSTALACION / HANDLING AND INSTALLATION

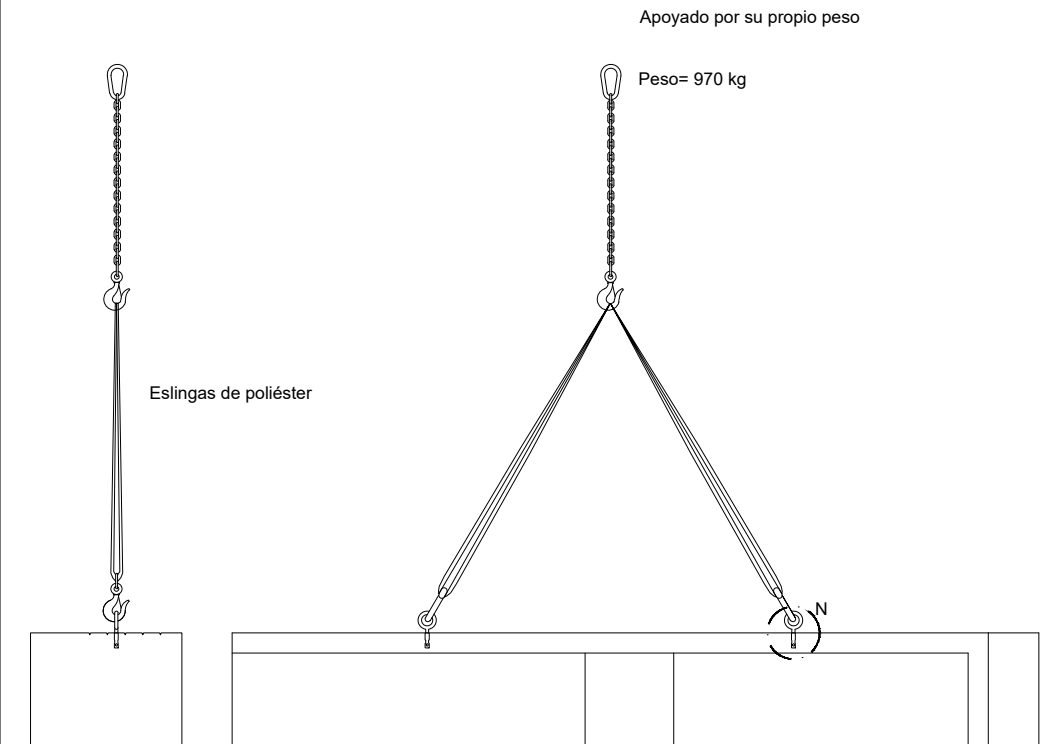

ESPECIFICACIONES / SPECIFICATIONS

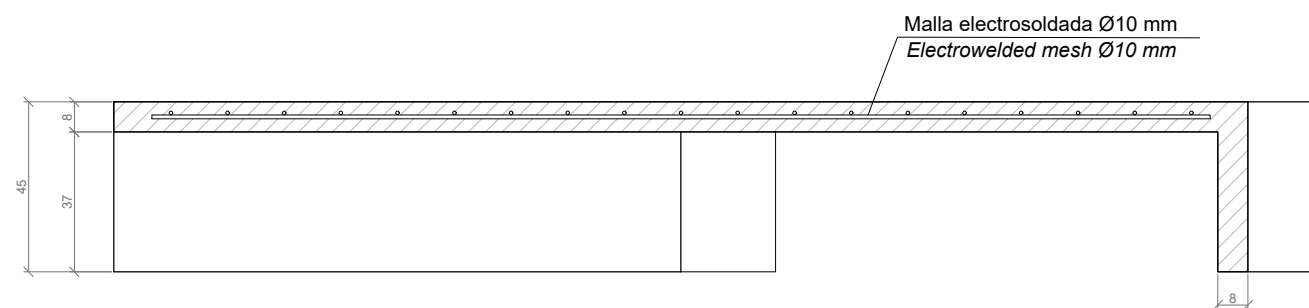

SECCION / SECTION

Casquillo elevación M16
Lifting socket M16

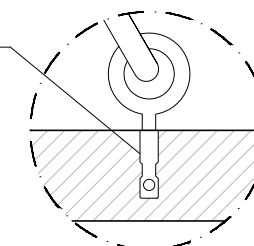

DETALLE N / DETAIL N