

CARACTERISTICAS / FEATURES

Material hormigón Petra 1
Acabado decapado e hidrofugado
Dimensiones l. 200, a. 50, h. 45 cm
Color ver carta de colores
Fijación apoyado por su propio peso y con resina epoxi
Peso 426 kg
Palet 210 x 55 x 65h cm
Peso palet 450 kg

Material concrete Petra 1
Finish scaled and waterproofed
Dimensions l.200, w.50, h.45 cm
Colour see colour catalogue
Fixing by its own weight and with epoxy resin
Weight 426 kg
Pallet 210 x 55 x 65 cm
Weight pallet 450 kg

diseñador / design: magourban

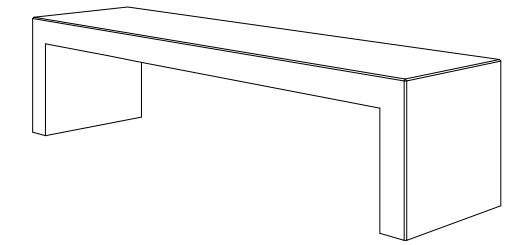

TARGA B 50

GEOMETRIA / GEOMETRY

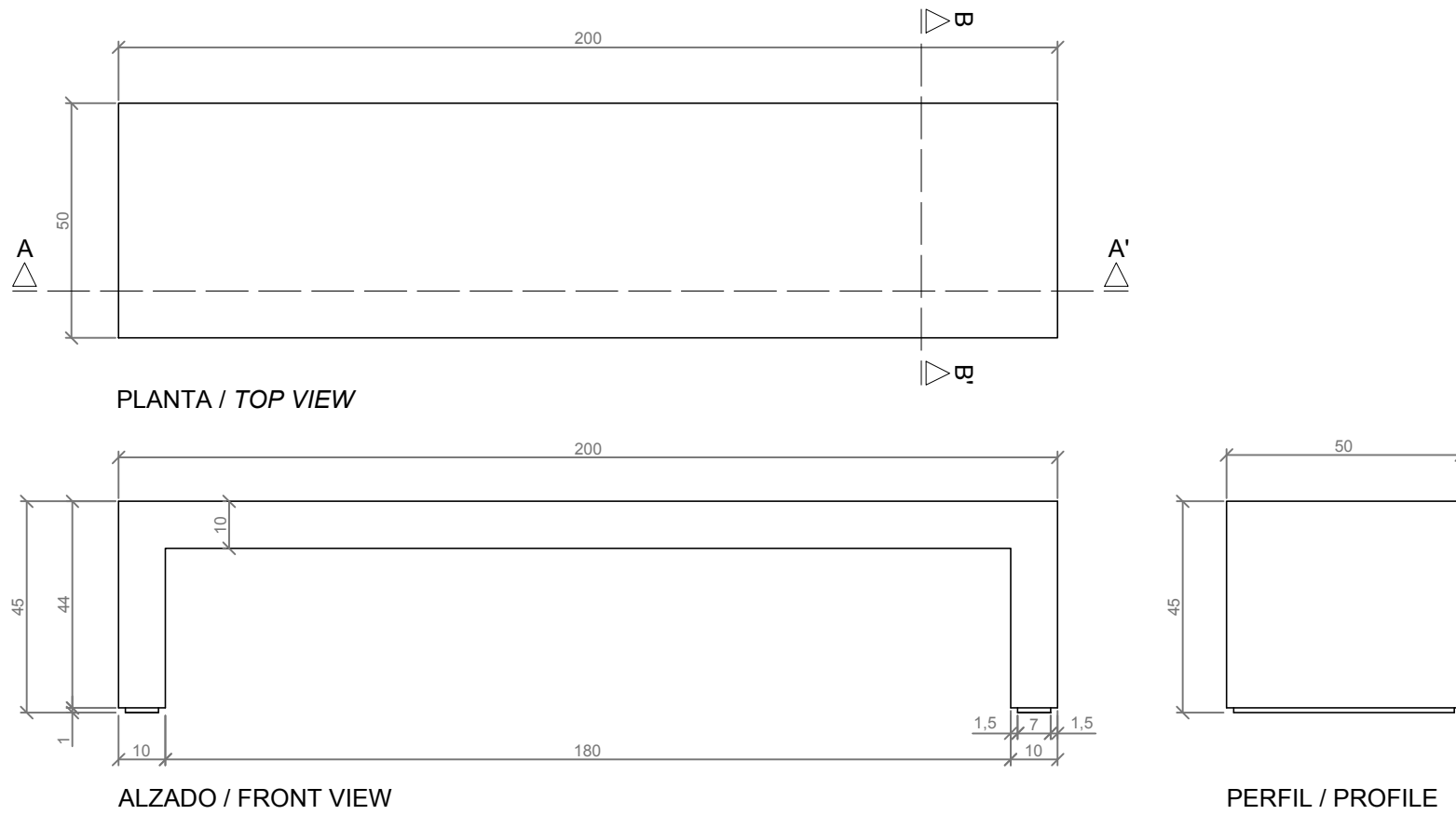

ESCALA / SCALE 1/20

MANIPULACION E INSTALACION / HANDLING AND INSTALLATION

- 1 Elevar y enroscar varillas inferiores
Lifting and screwing lower rods

MUY IMPORTANTE / VERY IMPORTANT
 Proteger las esquinas con espuma del embalaje
Protect the corners with packing foam

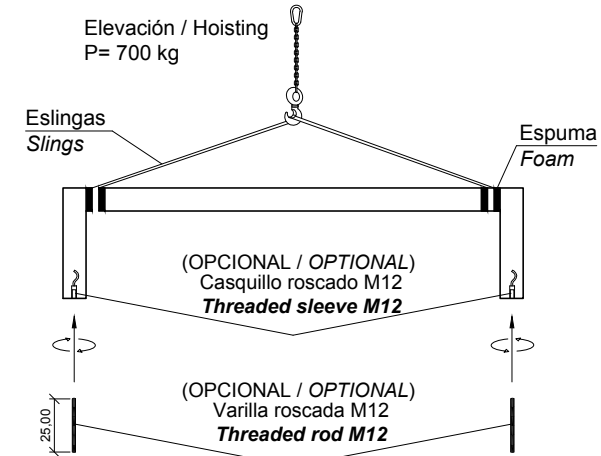

- 3 Verter resina epoxi
Pour epoxy resin

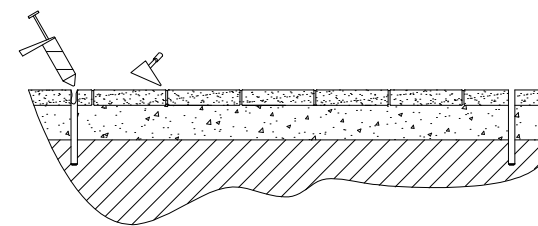

- 2 Perforar agujeros de Ø1,4 cm
Drill holes of Ø1.4 cm

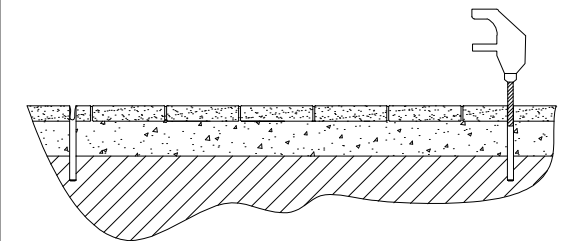

- 4 Insertar las varillas M12 en los agujeros
Insert metal rods M12 in holes

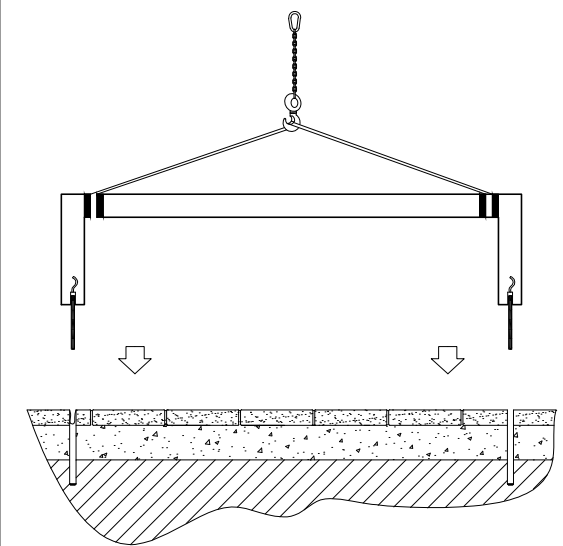

ESPECIFICACIONES / SPECIFICATIONS

Detalle D, OPCIONAL
 (Instalación con varilla metálica)
Detail D (OPTIONAL)
 (Installation with metal rod)

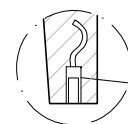

Casquillo M12 - Acero zincado alta precisión
Threaded sleeve M12 - Galvanized steel high precision

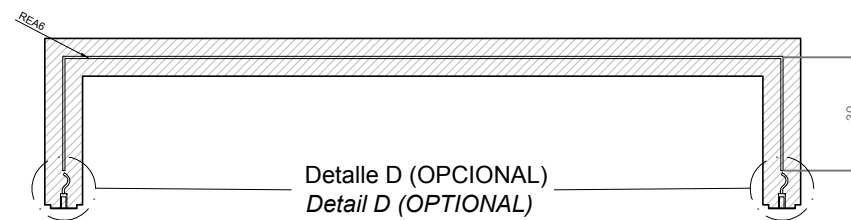

Malla electrosoldada con barra de Ø6 mm cada 150 mm
Electrically welded grating rods of Ø6 mm each 150 mm

