

CARACTERISTICAS / FEATURES

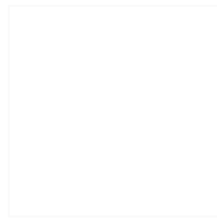

Material hormigón Petra 1
Acabado decapado e hidrofugado
Dimensiones l. 40, a. 40, h. 45 cm / l. Ø50, h. 45 cm
Color ver carta de colores
Fijación apoyado por su propio peso o con resina epoxi
Peso - kg
Palet 70 x 70 cm (1un)
 120 x 80 cm (2un)

Material precast concrete Petra 1
Finish scaled and waterproofed
Dimensions l. 40, w. 40, h. 45 cm / l. Ø50, h. 45 cm
Colour see colour catalogue
Fixing resting on the ground or with epoxy resin
Weight - kg
Pallet 70 x 70 cm (1un)
 120 x 80 cm (2un)

diseñador / design: magourban

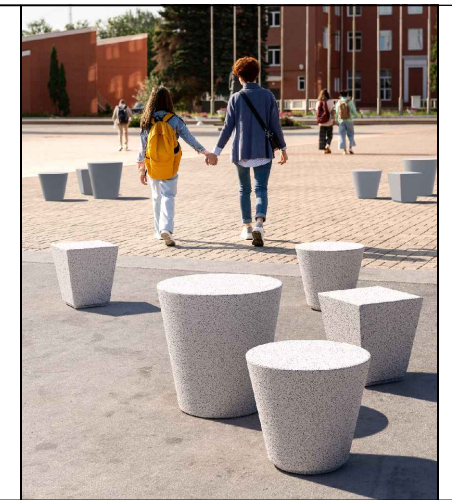

STOP AND GO

GEOMETRIA / GEOMETRY

STOP 64

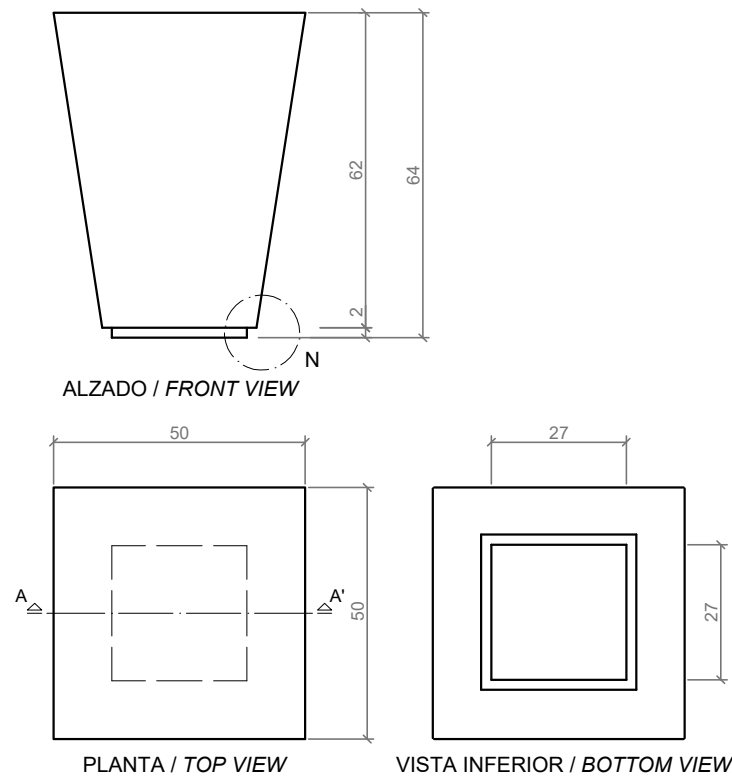

STOP 45

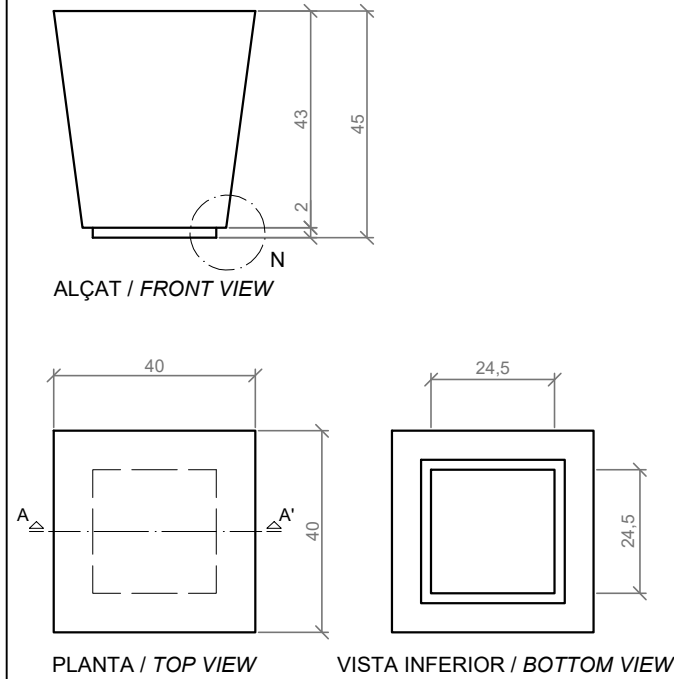

GO 45

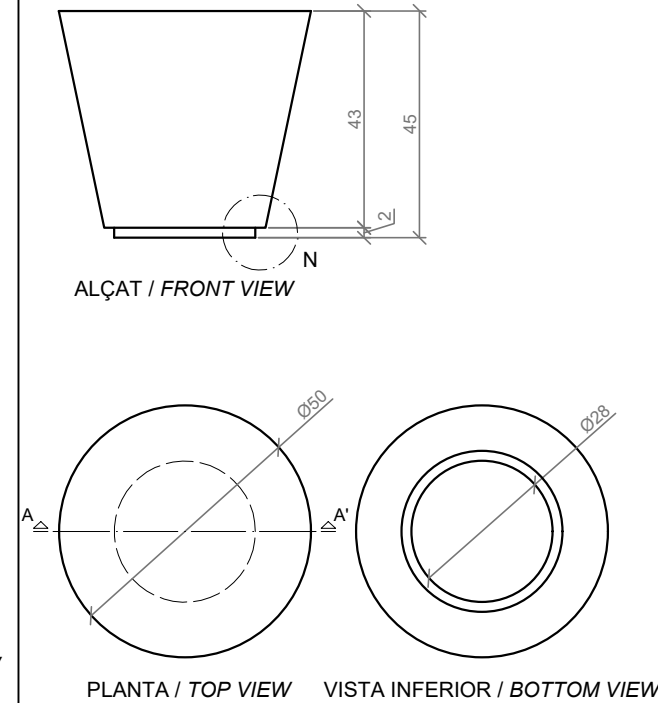

GO 60

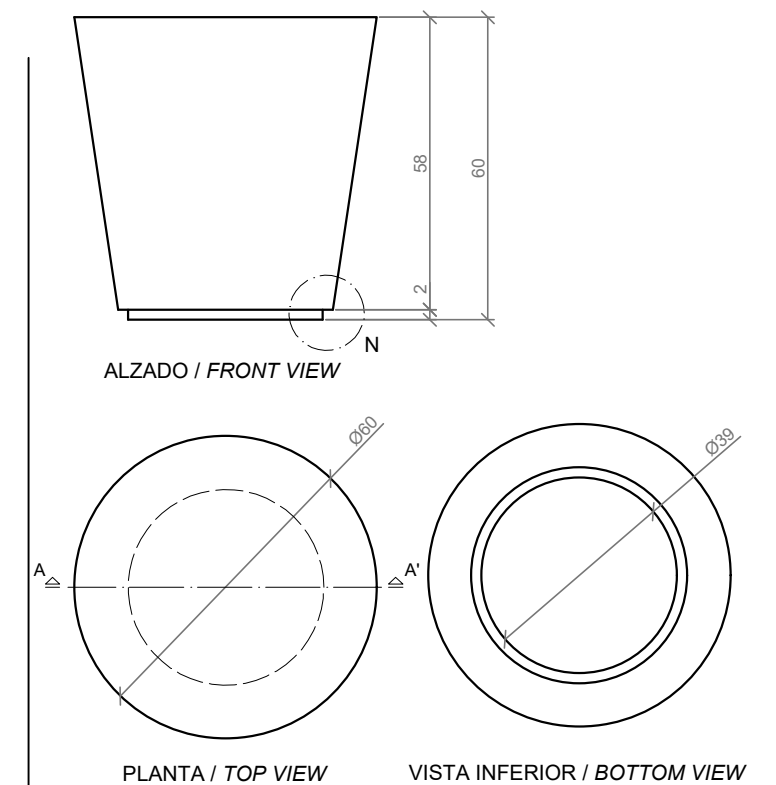

ESC. 1:15

ESPECIFICACIONES / SPECIFICATIONS

